

Feeder/Dispenser

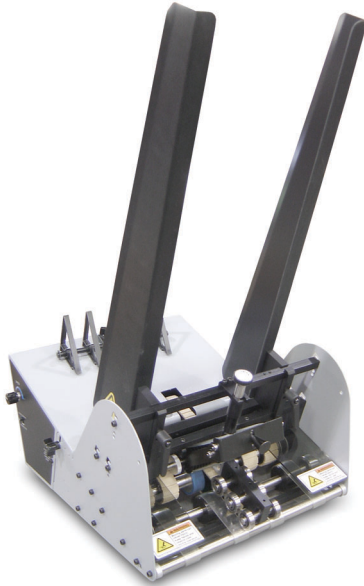

VALUE SERIES

Model V-710IJ



OVERVIEW

The V-710IJ is for production mailing operations that demand maximum throughput from their ink jet printing, labeling, and tabbing bases. The lightweight V-710IJ provides superior feeding to precisely separate and singulate many types and sizes of product. Job setups and changeovers are easily and quickly accomplished. The variable speed, clutch-free motor provides dependable feeding performance.

APPLICATIONS

- Ink jet bases
- Labeling bases
- Tabber bases
- Reinforcing machines

TECHNICAL DATA

Maximum Product Size:..... 12 W x 12 L in (305 x 305 mm)*
Minimum Product Size: 3.75 W x 3.75 L in (95 x 95 mm)
Optional: 2.5 W x 2.5 L in (63 x 63 mm)
Min/Max Product Thickness:003-.75 in (.076-19.1 mm)
Belt Speed: 5700 in/min (144780 mm/min)
Electrical Requirements:..... 115/230vac, 50/60Hz, 3A
Weight: 41 lbs. (18.6kg)
Warranty: Two-year limited

*Optional product size available

FEATURES

- Durable steel construction/powder coat paint
- Quality precision parts
- Quick access split shell design
- Variable speed DC motor
- Adjustable feed belts for added feeding performance
- Feeds tall stack heights of 8.5 x 11 inch and A4 sheets with ease
- Advancing gate enables maintenance without stopping a job
- Optional external run input for integrated start/stop control

DIMENSIONS

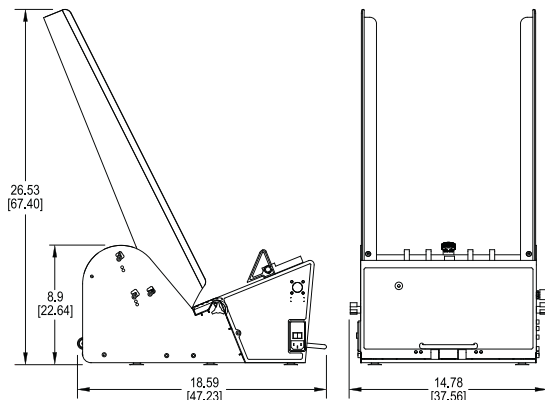

Thiele Technologies

103 Osborne Road • Minneapolis, MN 55432-3131 • USA

t 763.502.0000 • f 763.502.0100 • www.streamfeeder.com • E-mail: sales@streamfeeder.com