

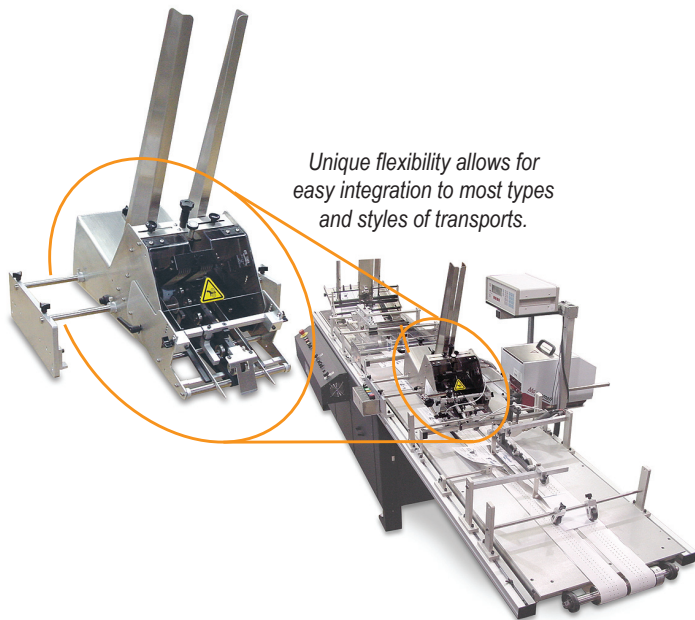

PRODUCT LINE

Tip-On / Affixing Model Converge 900



Unique flexibility allows for easy integration to most types and styles of transports.

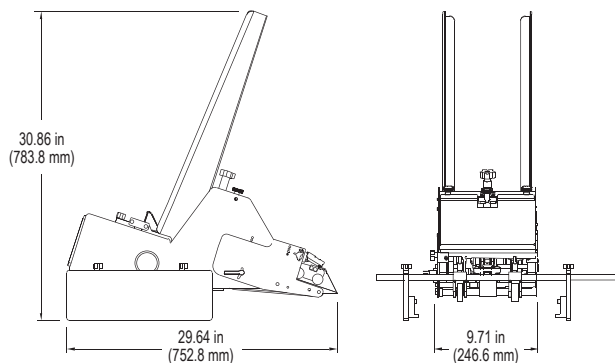

Specifications

Maximum Product Size:	7 W x 6 L in (177 x 152 mm)
Minimum Product Size:	2 W x 2.5 L in (50 x 63 mm)
Min/Max Product Thickness:	.003-.250 in (.076 x 6.35 mm)
Belt Speed:	24,000 in/min (609,600 mm/min)
Placement Tolerance:	Steady speed up to +/- 1/16 in (1.58 mm)
Electrical Requirements:	115/230vac, 10A
Air Requirements:	4-6 CFM
Weight:	60 lbs. (27.22 kg)
Warranty:	One-year limited

Overview:

The Converge 900 is the most accurate, innovative high-speed product placement solution available. The Converge 900 precisely places products at high-speed onto carrier pieces traveling on a variety of transports. Singulates and dispenses the widest range of material types and sizes.

Applications:

- Gift cards onto a hanging backer
- Promotional documents onto magazines
- Folded documents onto cartons/boxes
- Embossed credit cards onto folded/unfolded paper carriers

Features:

Servo Motor and Controller

Advantages:

High-speed stopping accuracy.

Benefits:

+/- 1/16" Placement tolerance.

Modular Design

Can be purchased stand-alone, added to existing equipment or configured as a complete system. Use on multiple pieces of host equipment.

Low initial investment. Enables system to process largest variety of products. Utilizes existing resources.

Placement Position Adjustment

Placement position can be set or adjusted on the fly.

Quickly & accurately adjust product position on the run.

Vacuum Assist

Vacuum feed capability is standard.

No struggling with coated or slick stocks.

Articulating Discharge Section

Height can be raised without changing tip-on position.

Increases feeder mounting options and system flexibility.

Optional Alignment Section

True fully-adjustable side registration.

Tighter tolerances and improved product quality.

Barry-Wehmiller

103 Osborne Road · Minneapolis, MN 55432-3131 · USA
(763) 502-0000 · www.streamfeeder.com · E-mail: sales@streamfeeder.com

ACCRAPLY

Barry-Wehmiller Company



pneumatic SCALE ANGELUS

Thiele Technologies

DESIGN GROUP

Barry-Wehmiller International Resources

Hayssen Sandiacre

Marquip Ward United

Fleetwood Goldco Wyard